



# Label Applicator Machine

## Instruction Manual

**KL18319**



**KegLand Distribution PTY LTD**

**[www.KegLand.com.au](http://www.KegLand.com.au)**

 **WARNING** 

**DO NOT PLACE ANY BODY PARTS NEAR ANY MOVING PARTS WHILE THE MACHINE IS PLUGGED IN. ENSURE THE MACHINE IS UNPLUGGED BEFORE PLACING ANY BODY PARTS CLOSE TO ANY MOVING PARTS**

### Initial Setup

**Step 1.** Attach the paper tray bracket to the Label applicator machine with the three small screws provided.



**Step 2.** Assemble the paper tray as shown below and secure the position of the two perspex disks with a socket head screw, to secure the paper roll in place between the Perspex disks.

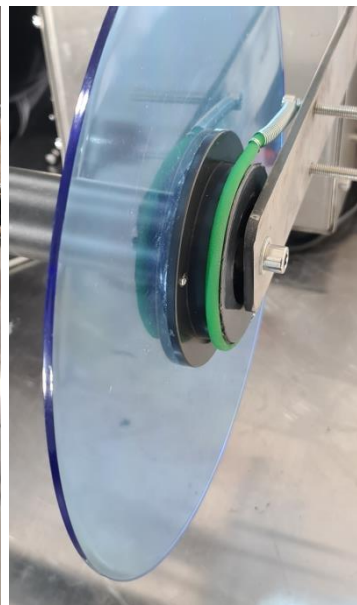

**Step 3.** Feed paper through the machine in the direction of the red line as shown below:

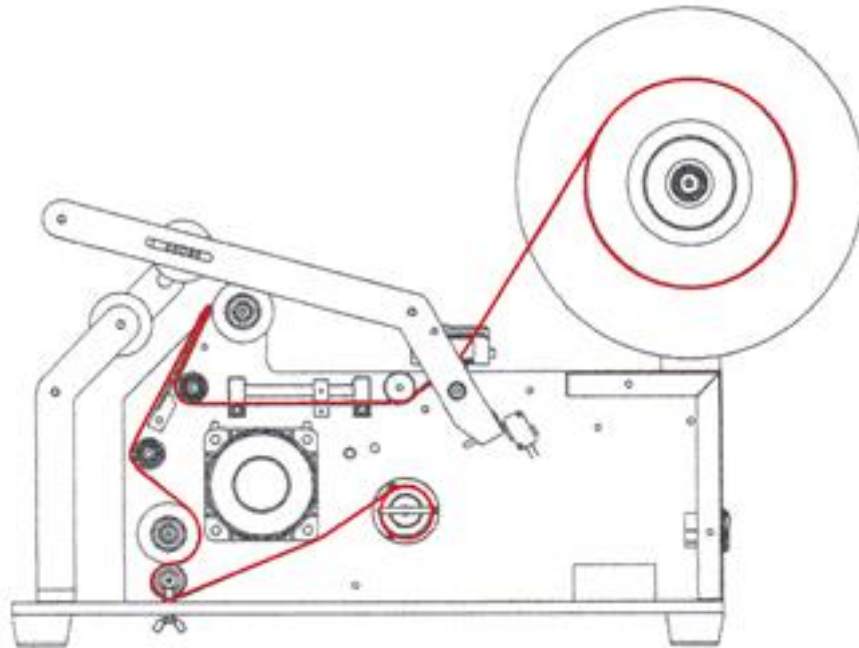

1. Feed the label under the guide rod and adjust the guide disks according to the height of the label



Guide rod



Guide disks

2. Feed the label under the transition roller and up the peeling plate



3. Feed the label over the peeling plate, behind the first soft pull roller and then between the second soft pull roller and the knurled pull roller. Then feed the label back underneath the knurled pull roller.



The gap between the second soft pull roller and the knurled pull roller can be opened by unscrewing the wing nuts underneath the knurled pull roller to make it easier to feed the paper between two. The wing nuts can then be tightened and the second soft pull roller rotated to feed the label through these two rolls and underneath the knurled pull roller.



4. Feed the label over the feed roller and secure in place with the clip

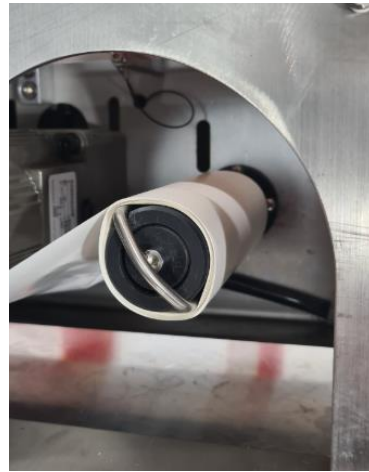
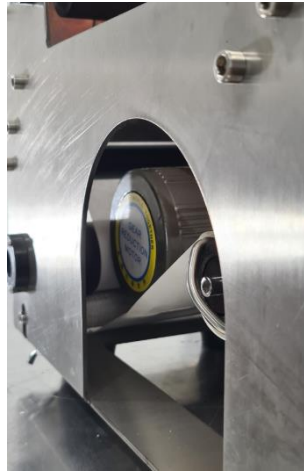

- Step 4.** Move the position of the sensor according to the label width.

It is suggested that a small section of adhesive is visible at the pressing can roller as shown below to make it easier to determine where the can should be placed on the can support roller and labelling soft roller.



The peeling plate should be as close as possible to the labelling soft roller, but not touching.

**Step 5.** Adjust the distance between the support roller and labelling soft roller according to the diameter of the can. Also adjust the position of the pressing roller on the swing arm so it sits centrally above the can. After adjusted, tighten the wing nuts.



**Step 6.** Adjust the amount of thread showing on the touch rod screw such that the microswitch is activated just before the pressing roller touches the can. Activation of the microswitch can be identified by an audible clicking sound.



Touch rod screw



Adjust the amount of thread showing here to alter when the microswitch is activated



## Operation

1. Place a can on the support roller and labelling soft roller
2. Align the can with the label
3. Pull the swing arm down until the pressing roller touches the can
4. Hold the swing arm down until the label is applied
5. Return the swing arm to its original position and remove the labelled can.

## Calibration of sensor

1. Load a label onto the paper tray and feed through the machine and attach to the feed roller.
2. Place the sensor over the first label.
3. Press the (+) and (-) buttons simultaneously. The red light on the sensor will begin brightly flashing red.
4. Move the sensor over to the second label.
5. As the sensor passes over the gap a yellow light will flash and then it will continue flashing red.
6. Press the (-) button to lock the sensor and store this information.
7. The motor should now stop running when the sensor passes over the gap between labels.

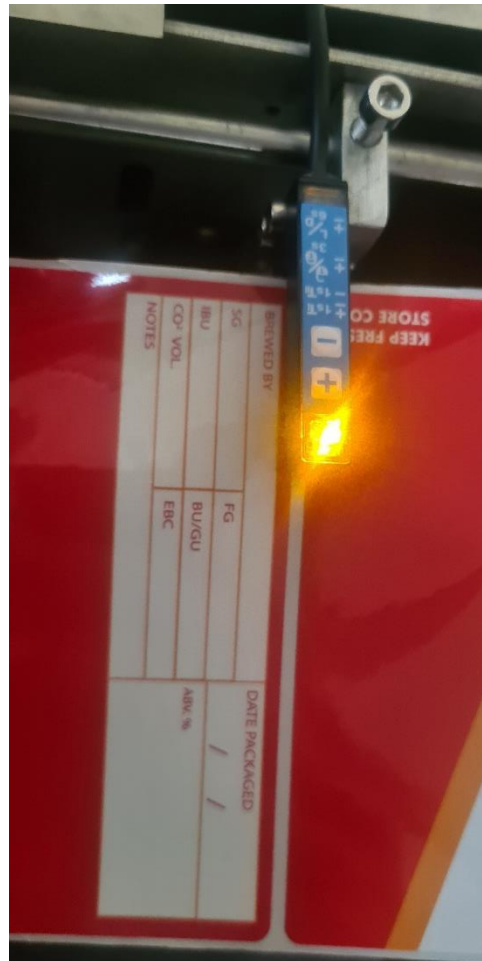



## Warranty and Support (Australia)

The Label Applicator Machine comes with a 12 month warranty when sold in Australia.

To lodge a warranty claim in Australia please forward as many visual pieces of supporting information and a detailed description of your issue to [beer@kegland.com.au](mailto:beer@kegland.com.au)

If you purchased your unit from a distributor in Australia or internationally, you will be required to go through their warranty claims process.

*For a full terms and conditions, please visit our website here -> [Terms & Conditions](#)*

For technical support with the Label Applicator Machine please email [beer@kegland.com.au](mailto:beer@kegland.com.au)